

**STOPDIGGING!**



**POST SCREW SGS**

Post screws replace and outperform concrete posts across a whole range of structures. They make any project faster and easier without sacrificing strength, longevity or cost. Post screws are used for installing supports for fences, carports, barriers, and other structures. The U profile creates a strong bond with the supported post, with the added advantage of allowing wood to dry properly and not decay buried in the ground.



**EXAMPLE OF USAGE AREAS**

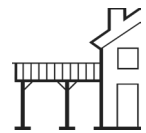
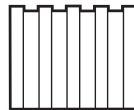

\*Terms apply, see product warranty

# STOPDIGGING!®



	SGS	70x935	95x935	70x1200	95x1200	
	Art no	2001	2002	2003	2004	
A	Screw thickness	2				mm
B	Screw length	935		1200		mm
C	Outer diameter	67				mm
D	Helix length	280				mm
E	Helix spacing	40				mm
F	Helix height	10				mm
G	Height	200				mm
H	Thickness	5				mm
I	Opening	70	95	70	95	mm
J	Width	30				mm
K	Hole diameter	11				mm

**CERTIFICATE**

Material	ISO 630 FE 360A
Product	EN 1090
Galvanization	EN 1461
Manufacturing process	ISO 9001:2015
Installation process	ISO 9001:2015
*Expected min. service life	100 years

UKCA no. 2400-CPR-20120001  
Codemark no. CMNZ70132

Compression capacity	6,0	12,5	kN
Tensile capacity	4,5	6,5	kN
Lateral capacity	3,0	4,5	kN

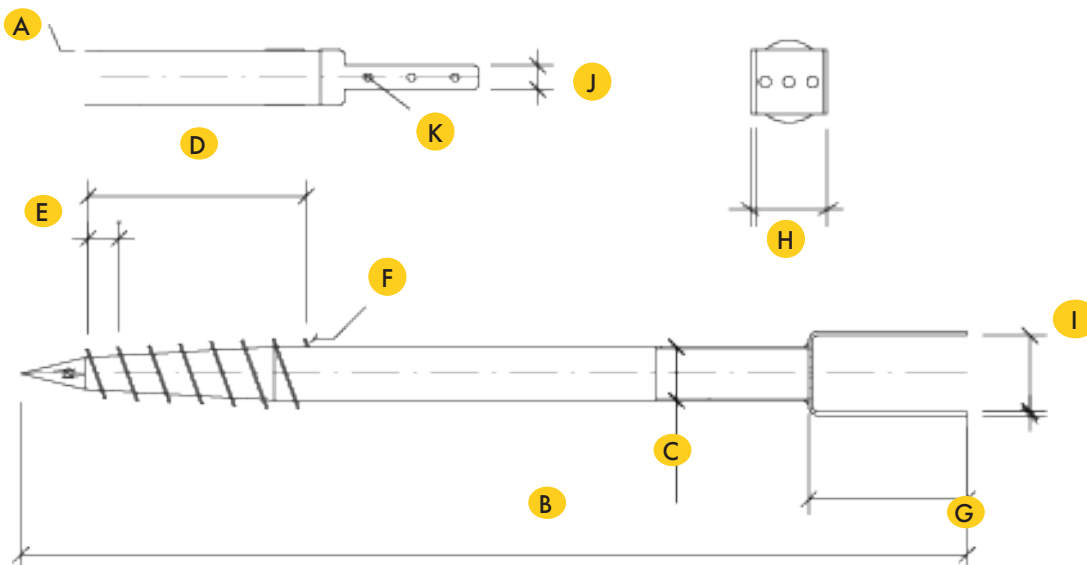

\*Terms apply, see product warranty

# STOPDIGGING!®



	SGS	70x935	95x935	70x1200	95x1200	
	Art no	2001	2002	2003	2004	
A	Screw thickness	0,08				in.
B	Screw length	36,8		47,2		in.
C	Outer diameter	2,64				in.
D	Helix length	11,0				in.
E	Helix spacing	1,57				in.
F	Helix height	0,39				in.
G	Height	7,87				in.
H	Thickness	0,2				in.
I	Opening	2,76	3,74	2,76	3,74	in.
J	Width	1,18				in.
K	Hole diameter	0,43				in.

**CERTIFICATE**

Material	ISO 630 FE 360A
Product	EN 1090
Galvanization	EN 1461
Manufacturing process	ISO 9001:2015
Installation process	ISO 9001:2015
*Expected min. service life	100 years

UKCA no. 2400-CPR-20120001  
Codemark no. CMNZ70132

Compression capacity	611	1274	kg
Tensile capacity	48	663	kg
Lateral capacity	306	458	kg

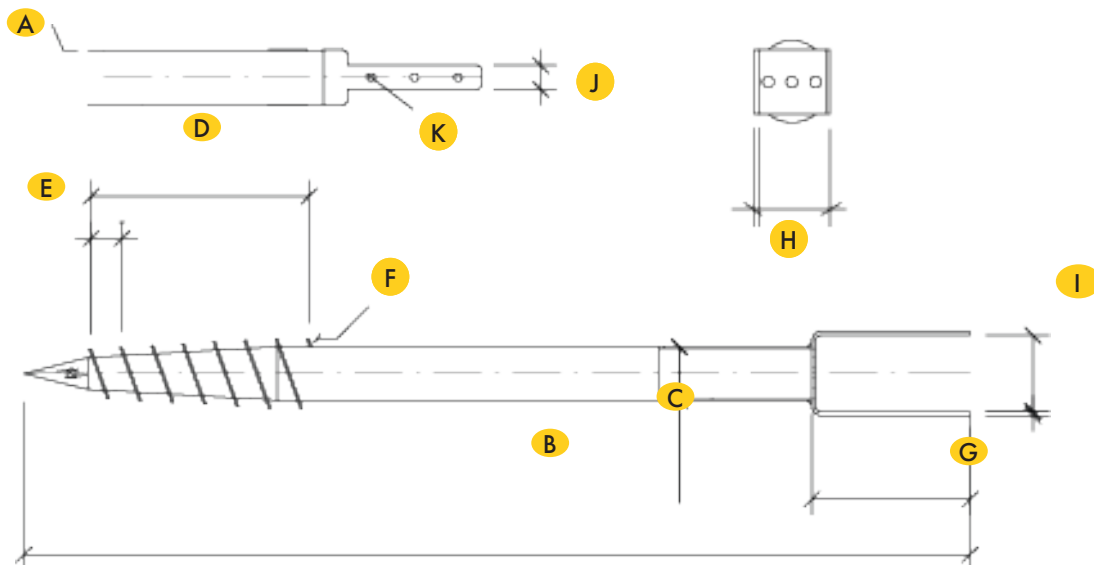

\*Terms apply, see product warranty