

**STOPDIGGING!®**



**ADAPTER SCREW SGC**

The adapter screw has a round mounting plate with a series of slots and a threaded M20 hole in the centre. This is designed to fasten any of our many applications depending on the type of foundation you need. The adapter screw also provides a great deal adjustability in all directions. Available applications include the beam bracket, post bracket, plate and L-support which make it a very versatile support. There is almost nothing we cannot securely attach! This makes it ideal for a variety of structures such as living quarters on construction sites, sound dampening boards, greenhouses, solar racks, and prefabricated houses.



**EXAMPLE OF USAGE AREAS**

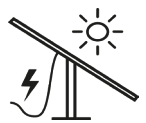

\*Terms apply, see product warranty

# STOPDIGGING!®



	SGC76	865	1200	1600	2000	2500	
	Art no	4030	4031	4032	4033	4034	
A	Screw thickness	4		3,5			mm
B	Screw length	865	1200	1600	2000	2500	mm
C	Outer diameter	76					mm
D	Helix height	480	840	900			mm
E	Helix spacing	60					mm
F	Helix length	10					mm
G	Thickness	8					mm
H	Plate diameter	200					mm
I	Fixing hole length	60					mm
J	Fixing hole width	15					mm
K	Thread, fixing holes	M20					

**CERTIFICATE**

Material	ISO 630 FE 360A
Product	EN 1090
Galvanization	EN 1461
Manufacturing process	ISO 9001:2015
Installation process	ISO 9001:2015
Expected min. service life *	125 years

UKCA no. 2400-CPR-20120001  
Codemark no. CMNZ70132

Compression capacity	13,5	25,0	35,0	45,0	55,0	kN
Tensile capacity	7,0	12,5	21,5	34,0	41,5	kN
Lateral capacity	3,5	6,0	8,5	11,5	14,5	kN

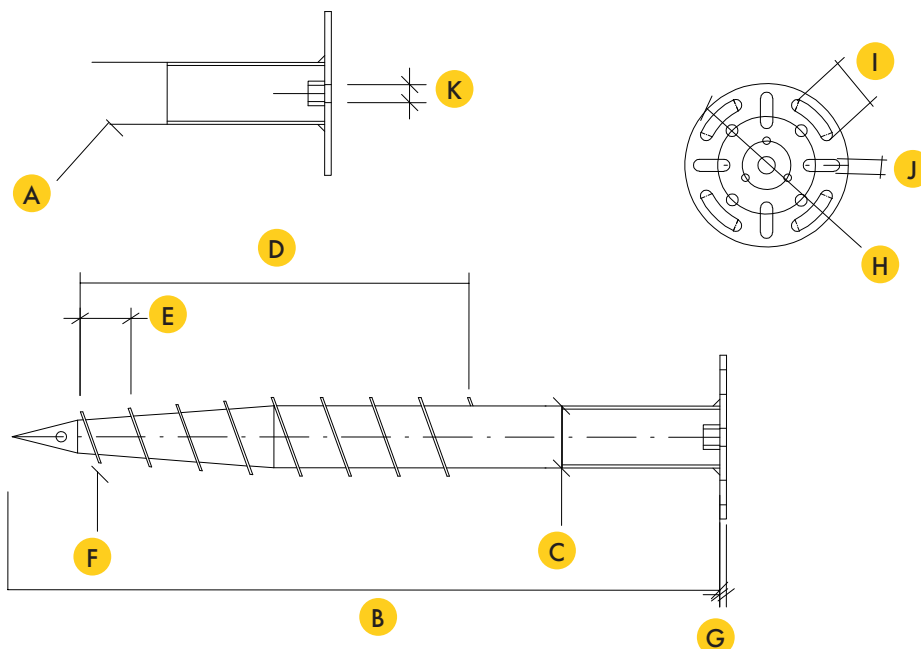

\*Terms apply, see product warranty

# STOPDIGGING!®



	SGC89	1200	1600	2000	2500	3000	
	Art no	4045	4036	4037	4038	4019	
A	Screw thickness	4		5		4	mm
B	Screw length	1200	1600	2000	2500	3000	mm
C	Outer diameter	89					mm
D	Helix length	900	1200	1500			mm
E	Helix spacing	60					mm
F	Helix height	10					mm
G	Thickness	8					mm
H	Plate diameter	200					mm
I	Fixing hole length	45					mm
J	Fixing hole width	15					mm
K	Thread, fixing holes	M20					

**CERTIFICATE**

Material	ISO 630 FE 360A
Product	EN 1090
Galvanization	EN 1461
Manufacturing process	ISO 9001:2015
Installation process	ISO 9001:2015
Expected min. service life*	125 years

UKCA no. 2400-CPR-20120001  
Codemark no. CMNZ70132

Compression capacity	37,5	58,0	72,0	82,0	91,5	kN
Tensile capacity	18,0	36,0	53,0	58,0	65,0	kN
Lateral capacity	9,5	13,0	17,5	22,0	24,5	kN

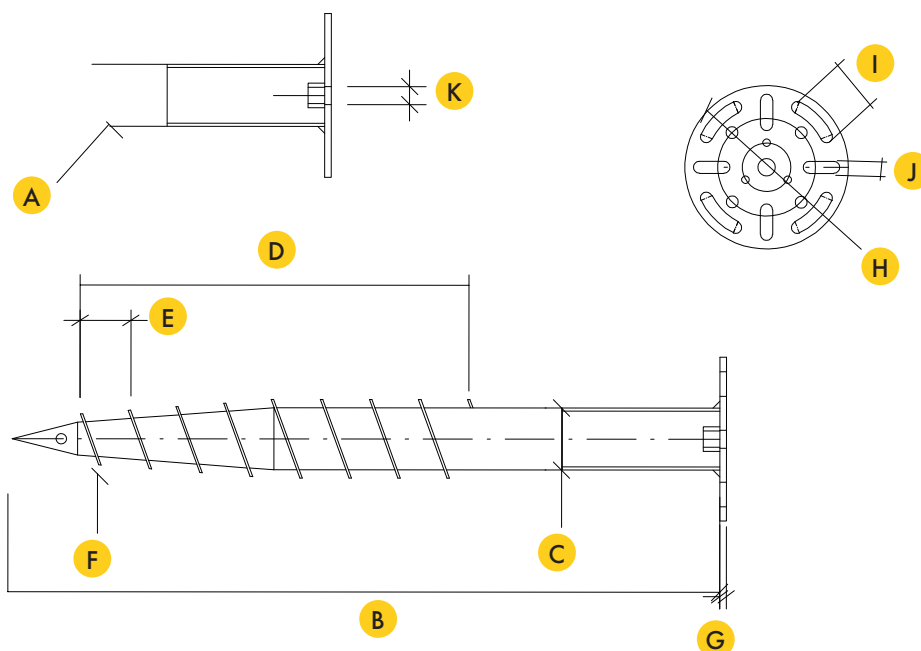

\*Terms apply, see product warranty

# STOPDIGGING!®



	SGC114	1600	2000	
	Art no	4056	4057	
A	Screw thickness	4	4	mm
B	Screw length	1600	2000	mm
C	Outer diameter	114		mm
D	Helix length	1200	1500	mm
E	Helix spacing	50		mm
F	Helix height	10		mm
G	Thickness	8		mm
H	Plate diameter	230		mm
I	Fixing hole length	45		mm
J	Fixing hole width	15		mm
K	Thread, fixing holes	M20		

Compression capacity	66,5	82,5	kN
Tensile capacity	41,0	61,5	kN
Lateral capacity	15,0	20,0	kN

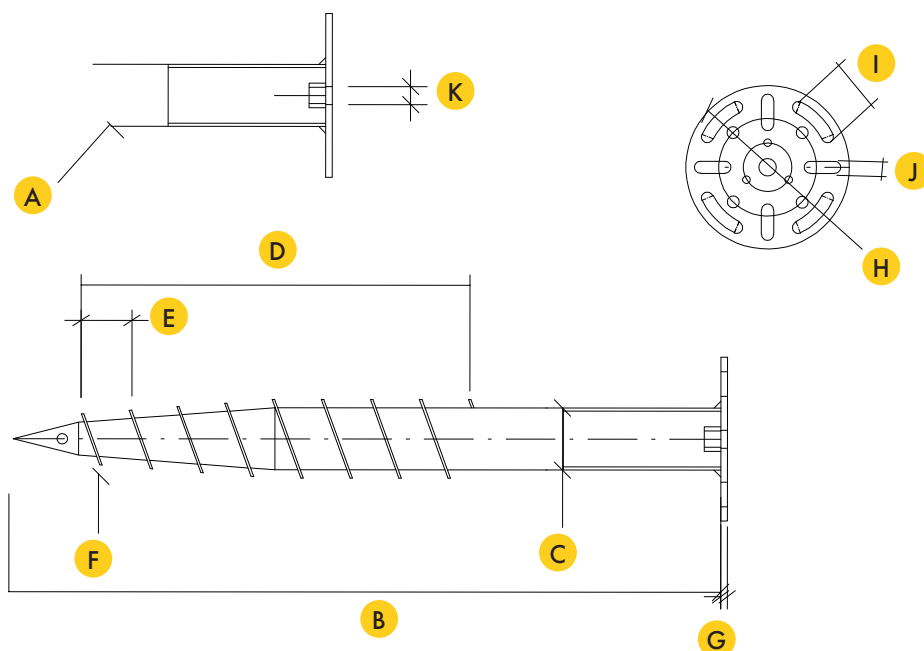

## CERTIFICATE

Material	ISO 630 FE 360A
Product	EN 1090
Galvanization	EN 1461
Manufacturing process	ISO 9001:2015
Installation process	ISO 9001:2015
Expected min. service life*	125 years

UKCA no. 2400-CPR-20120001

Codemark no. CMNZ70132



\*Terms apply, see product warranty

# STOPDIGGING!®



	SGC76	865	1200	1600	2000	2500	
	Art no	4030	4031	4032	4033	4034	
A	Screw thickness	0,16					in.
B	Screw length	34,1	47,2	63	78,7	98,4	in.
C	Outer diameter	3					in.
D	Helix height	18,9	33,1	35,4			in.
E	Helix spacing	2,36					in.
F	Helix length	0,39					in.
G	Thickness	0,32					in.
H	Plate diameter	7,87					in.
I	Fixing hole width	0,59					in.
J	Fixing hole length	2,36					in.
K	Thread, fixing holes	M20					

**CERTIFICATE**

Material	ISO 630 FE 360A
Product	EN 1090
Galvanization	EN 1461
Manufacturing process	ISO 9001:2015
Installation process	ISO 9001:2015
Expected min. service life *	125 years

UKCA no. 2400-CPR-20120001  
Codemark no. CMNZ70132

Compression capacity	1371	2549	3569	4589	5608	kg
Tensile capacity	714	1275	2192	3467	4232	kg
Lateral capacity	357	612	867	1173	1479	kg

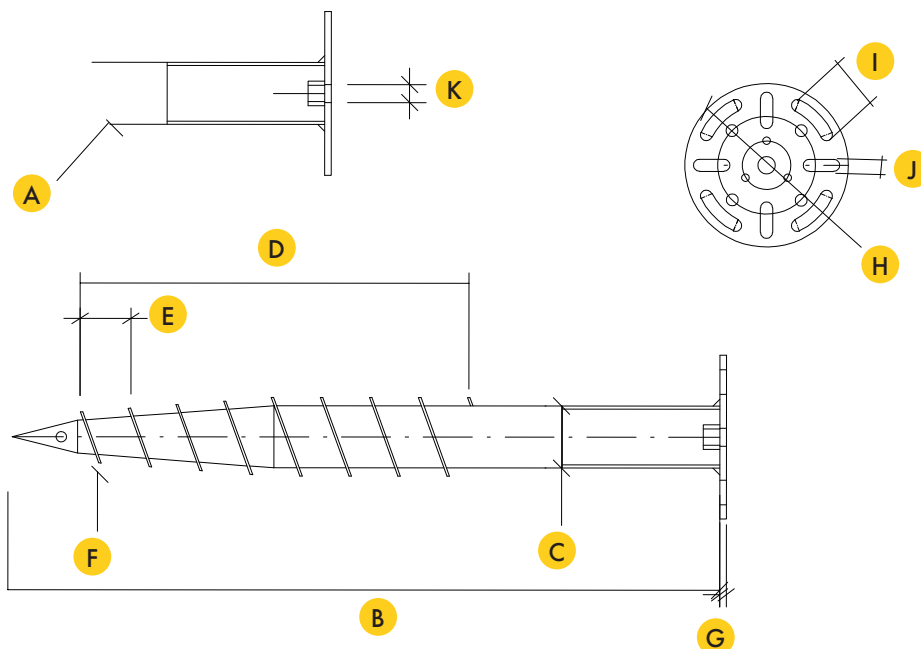

\*Terms apply, see product warranty

# STOPDIGGING!®



	SGC	1200	1600	2000	2500	3000	
	Art no	4045	4036	4037	4038	4019	
A	Screw thickness	0,16		0,20		0,16	in.
B	Screw length	47,2	63	78,7	98,4	118,1	in.
C	Outer diameter	3,5					in.
D	Helix length	35,4	47,2	59,1			in.
E	Helix spacing	2,36					in.
F	Helix height	0,39					in.
G	Thickness	0,32					in.
H	Plate diameter	7,87					in.
I	Fixing hole length	1,77					in.
J	Fixing hole width	0,59					in.
K	Thread, fixing holes	M20					

**CERTIFICATE**

Material	ISO 630 FE 360A
Product	EN 1090
Galvanization	EN 1461
Manufacturing process	ISO 9001:2015
Installation process	ISO 9001:2015
Expected min. service life *	125 years

UKCA no. 2400-CPR-20120001  
Codemark no. CMNZ70132

Compression capacity	3824	5914	7342	8362	9330	kg
Tensile capacity	1836	3671	5405	5914	6628	kg
Lateral capacity	969	1326	1784	2243	2498	kg

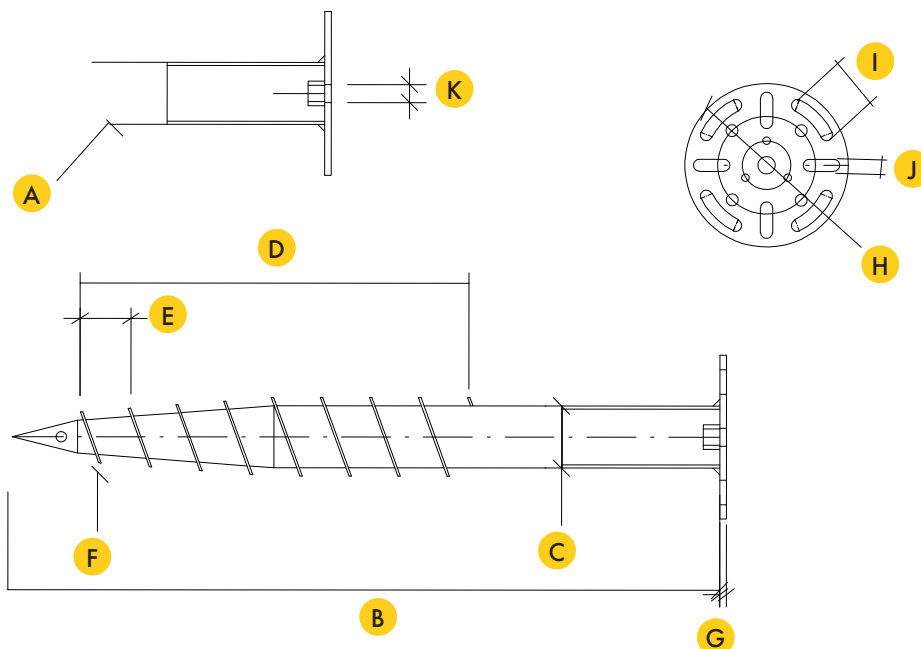

\*Terms apply, see product warranty

# STOPDIGGING!®



	SGC114	1600	2000	
	Art no	4056	4057	
A	Screw thickness	0,16	0,16	in.
B	Screw length	63	78,7	in.
C	Outer diameter	4,49		in.
D	Helix length	47,2	59,1	in.
E	Helix spacing	1,97		in.
F	Helix height	0,39		in.
G	Thickness	0,31		in.
H	Plate diameter	9,06		in.
I	Fixing hole length	1,77		in.
J	Fixing hole width	0,59		in.
K	Thread, fixing holes	M20		

**CERTIFICATE**

Material	ISO 630 FE 360A
Product	EN 1090
Galvanization	EN 1461
Manufacturing process	ISO 9001:2015
Installation process	ISO 9001:2015
Expected min. service life *	125 years

UKCA no. 2400-CPR-20120001

Codemark no. CMNZ70132

Compression capacity	653	810	kg
Tensile capacity	402	603	kg
Lateral capacity	147	196	kg

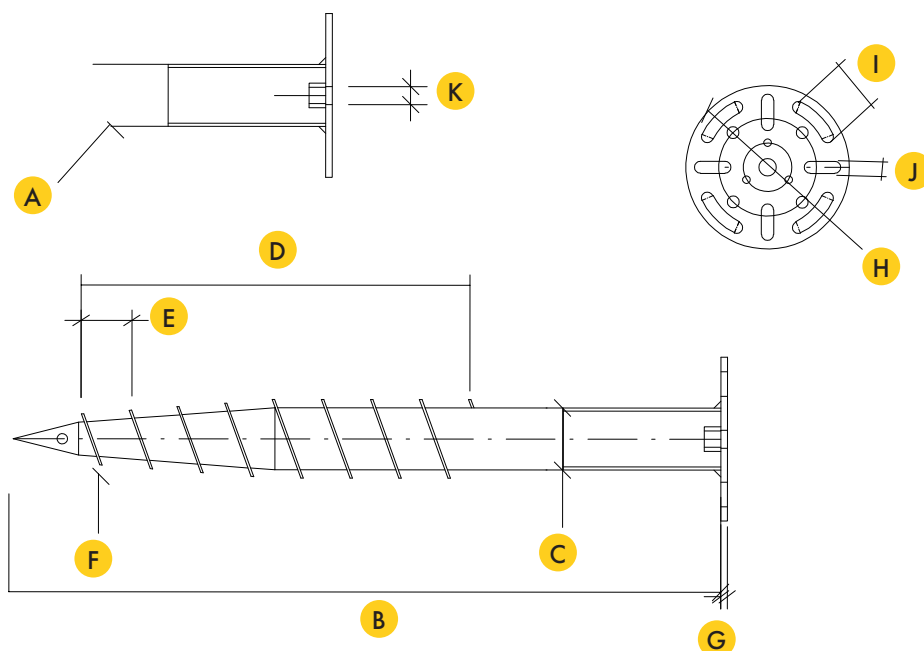

\*Terms apply, see product warranty